

## ML7421A,B

### Electric Linear Valve Actuators

#### SPECIFICATION DATA

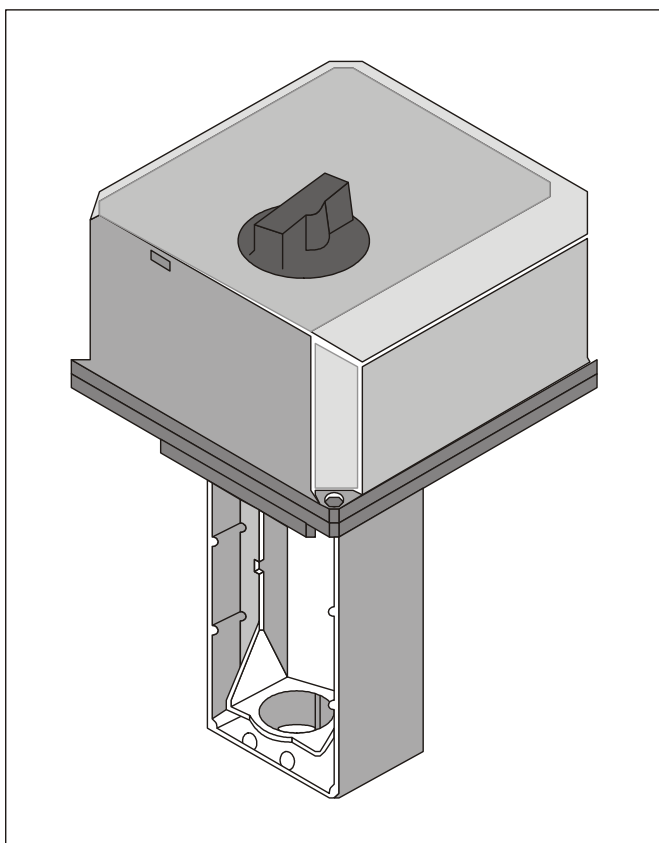

#### GENERAL

These actuators enable modulating control in conjunction with controls providing an analog output. The direction of movement is reversible by means of an internal selector plug.

They operate Honeywell's standard valves in heating, ventilation, and air conditioning (HVAC) applications.

#### FEATURES

- Quick and easy installation
- No separate linkage required
- No adjustments
- Force-limiting end switches
- Manual operator
- Synchronous motor
- Corrosion-resistant design
- Selectable 0...10 Vdc or 2...10 Vdc/ 0...20 mA or 4...20 mA input signal
- Position feedback signal
- Direct or reverse-acting adjustable
- Selectable stroke position on signal failure
- Maintenance-free

#### SPECIFICATIONS

##### Temperature Limits

|                          |   |
|--------------------------|---|
| Ambient operating limits | -10...+50 °C @ 5...95%rh                        |
| Ambient storage limits   | -40...+70 °C @ 5...95%rh                        |
| Medium valve temperature | Max. +150 °C (220 °C with High-Temperature Kit) |

##### Safety

|                         |  |
|-------------------------|--|
| Protection class        | III according to EN60730-1                   |
| Protection standard     | IP54 according to EN60529                    |
| Flame retardant housing | V0 according to UL94, with metal cable gland |
|                         | ≤45dB(A)                                     |

##### Noise level

##### Signals

|                                |                                 |
|--------------------------------|---------------------------------|
| Input range                    | Y = 0(2)...10 Vdc, 0(4)...20 mA |
| Input impedance                |                                 |
| for voltage                    | R <sub>i</sub> = 100 kΩ         |
| for mA                         | R <sub>i</sub> = 500 Ω          |
| Signal source output impedance | Max. 1 kΩ                       |
| Output voltage range           | Position: 2...10 Vdc            |
| Output load                    | Max. 1 mA                       |

##### Wiring

|                  |                                |
|------------------|--------------------------------|
| Wiring terminals | 1.5 mm <sup>2</sup>            |
| Cable entry      | M20x1.5 and knock-out for PG11 |

##### Material

|               |                  |
|---------------|------------------|
| Cover         | ABS-FR           |
| Yoke and Base | Aluminum diecast |

##### Weight

2.0 kg

##### Dimensions

see Fig. 2 and Fig. 3

| Model Number          | ML7421A3004   | ML7421B3003 |
|-----------------------|---|-------------|
| supply voltage        | 24 Vac (+10%/-15%); 50/60 Hz  |             |
| power consumption     | 14 VA (50 Hz) / 16 VA (60 Hz)   |             |
| signal input 0(2) Vdc | Actuator stem retracted. Two-way valve: open, three-way valve port A - AB: closed |             |
| signal input 10 Vdc   | Actuator stem extended. Two-way valve: closed, three-way valve port A - AB: open  |             |
| stroke                | 20 mm   | 38 mm       |
| run-time at 50 Hz     | 1.9 min   | 3.5 min     |
| nominal stem force    | 1800 N  |             |

## OPERATION

### General

The drive of a synchronous motor is converted into linear motion of the actuator stem by using a worm gear transmission.

The actuator stem is connected with the valve stem by a button keyed retainer connection.

Via installed microswitches, the internal force sensor switches off the actuator precisely when the nominal stem force is reached.

If used as a replacement of an already-installed actuator M7421A,B, the following issue is to observe:

- Permanent power supply (see section "Electrical Installation")

### Manual Operation

The actuators are equipped with a manual operator used in case of power failure. Manual operation is possible only after the power supply has been switched off or disconnected.

To operate, push the manual operator knob down and turn clockwise to move the stem upward and counter-clockwise to move the stem downward. If the actuator returns to automatic control, the manual operator knob unlocks automatically.

**NOTE:** Manual operation allows a very high closing force capable of jamming the actuator spindle and exceeding the rating of the force switches, so that the motor cannot move.

Therefore, after a manually close-off operation, it is necessary to release the spindle one turn by turning the manual operator knob, thus ensuring that the manual operator will automatically disengage on power resumption.

### Electrical Installation

24 V~ and 24 V<sub>L</sub> (see Fig. 3.) must be applied under all operating conditions.

Cable length/diameter for field mounting:

- Max. 200 m / 1.5 mm<sup>2</sup>

### Input Signal

The Vdc- or mA-input signal is selected by shifting jumper plug W4 (see Fig. 1). The factory setting of W4 is "Vdc". No external resistor for mA-input signal is necessary.

### Input Signal Range

The range of the analog input signal Y (0...10 Vdc / 0...20 mA or 2...10 Vdc / 4...20 mA) can be selected by changing the position of jumper plug W2 (Fig. 1). The factory set is at 0...10 Vdc.

### Direction of Action

The direction of action (direct or reverse) can be selected by changing the position of jumper plug W3 (Fig. 1). The factory set is: stem extends at increasing signal (direct acting).

**NOTE:** Jumper plugs W1, W2, W3, and W4 are accessible after the cover has been removed. They are located on top side of the printed circuit board (see Fig. 1).

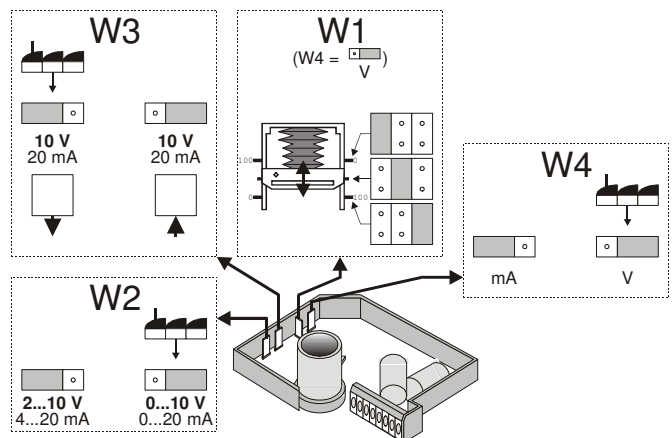

Fig. 1. Jumper plugs W1, W2, W3, W4

### Output Signal "POSITION"

An analog output signal 2...10 Vdc "POSITION" representing the actuator stroke 0...100% can be selected. It can be used for remote indication.

When the actuator stem is fully extended, the output signal is 10 Vdc.

### Y-Signal Override

To override the Y-signal, inputs 1 and 2 (see Fig. 3.) must be connected as follows:

- stem extended: 24 V<sub>L</sub> at input 1; input 2 not connected
- stem retracted: 24 V<sub>L</sub> at input 2; input 1 not connected

24 Vac power and ground must be permanently connected.

### Input Signal Failure

In case of a signal input (Y) e. g. a broken wire, the actuator will run to one of the three positions (possible only if W4 has been set to the "V" position):

- 0%: actuator stem position for 0(2) Vdc
- 50%: actuator stem in central position
- 100%: actuator stem position for 10 Vdc

The factory setting of W1 is "50%".

### Accessories

The following accessories are available upon request.

### Auxiliary Switches

The actuators can be equipped on-site with an auxiliary switch unit with two switches. Their switching points are adjustable over the full length of the actuator stroke.

The switches can be used e.g. to switch pumps or to provide remote indication of any stroke position.

A cable gland PG11 is delivered with the unit.





| Type  | for stroke     | Order No.    |
|---|----------------|--------------|
| auxiliary switches; 24 Vac / 5 (3) A (package contains 2 SPDT switches) | 20 mm<br>38 mm | 43191680-002 |

### High-Temperature Kit

Two options for applications with a medium valve temperature of +150...+220 °C are available for the following valves:

| Valve  | DN  | High Temperature Kit Order No. |
|--|---|--------------------------------|
| V5011A/V5011K<br>V5013A/V5013G<br>V5011R/V5013R<br>V5328A/V5329A | 15 - 40<br>15 - 40<br>15 - 50<br>15 - 32  | 43196000-001                   |
| V5011A<br>V5013A/V5013G<br>V5328A/V5329A<br>V5049A<br>V5050A     | 50<br>50<br>40 - 80<br>15 - 65<br>15 - 80 | 43196000-002                   |

## CLOSE-OFF PRESSURE RATINGS

| Stroke        | 20 mm   |                                     |      |      |      |      |      |      |      | 38 mm |     |     |     |     |
|---------------|---|-------------------------------------|------|------|------|------|------|------|------|-------|-----|-----|-----|-----|
|               | Valve   | mm                                  | 15   | 20   | 25   | 32   | 40   | 50   | 65   | 80    | 80  | 100 | 125 | 150 |
| Size          |   | inch                                | 1/2  | 3/4  | 1    | 1 ¼  | 1 ½  | 2    | 2 ½  | 3     | 3   | 4   | 5   | 6   |
| Valves        |   | Close-Off Pressure Ratings (in kPa) |      |      |      |      |      |      |      |       |     |     |     |     |
| V5011R        |  |                                     |      |      | 1600 | 1600 | 1500 | 850  |      |       |     |     |     |     |
| V5011K        |  |                                     |      |      | 1600 | 1600 |      |      |      |       |     |     |     |     |
| V5013R        |  |                                     |      |      | 1600 | 1600 | 1500 | 850  |      |       |     |     |     |     |
| V5015A        |   |                                     |      |      |      |      |      |      |      |       |     | 150 | 120 | 80  |
| V5328A        |   |                                     | 1600 | 1600 | 1600 | 1600 | 1300 | 750  | 470  | 230   |     |     |     |     |
| V5329A (PN16) |  |                                     |      |      |      |      | 1000 | 1000 | 1000 | 650   | 400 |     |     |     |
| V5329C (PN6)  |  |                                     |      |      |      |      |      | 600  | 600  | 600   | 400 |     |     |     |
| V5049A        |   |                                     | 2500 | 2500 | 2500 | 2000 | 1300 | 750  | 500  |       | 230 | 230 | 90  | 90  |
| V5050A        |   |                                     | 2500 | 2500 | 2500 | 2000 | 1300 | 750  | 500  | 230   |     | 230 | 90  | 90  |

 = Use 600 N actuator

For details on the valves, see the following Specification Data No.:

|        |               |              |               |
|--------|---------------|--------------|---------------|
| V5011R | EN0B-0064GE51 | V5328A/5049A | EN0B-0309GE51 |
| V5011S | EN0B-0085GE51 | V5329A/5050A | EN0B-0310GE51 |
| V5011K | EN0C-0560GE02 | V5095A       | EN0B-0412GE51 |
| V5013R | EN0B-0065GE51 |              |               |

## DIMENSIONS

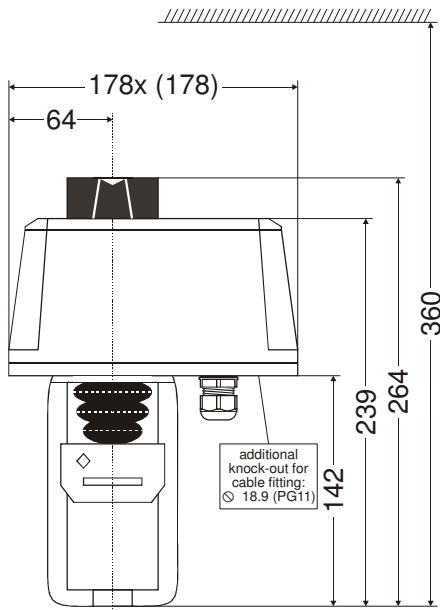

Fig. 2. ML7421A (dimensions in mm)

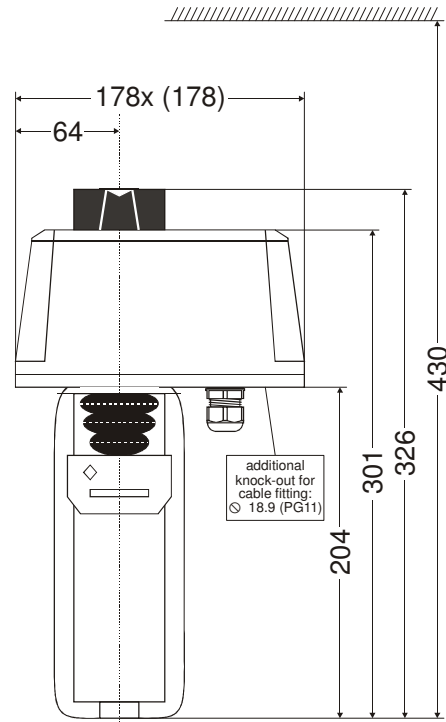

Fig. 3. ML7421B (dimensions in mm)

## Wiring

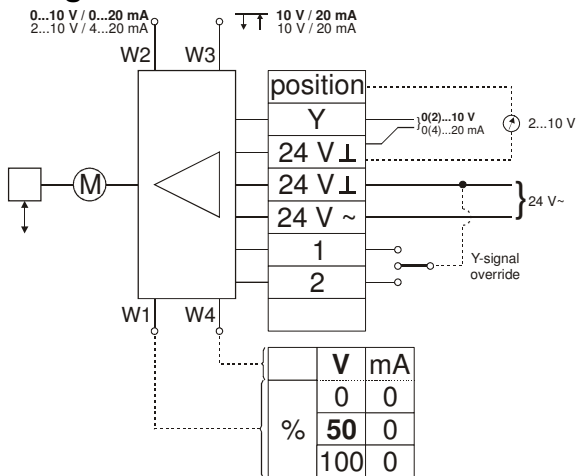
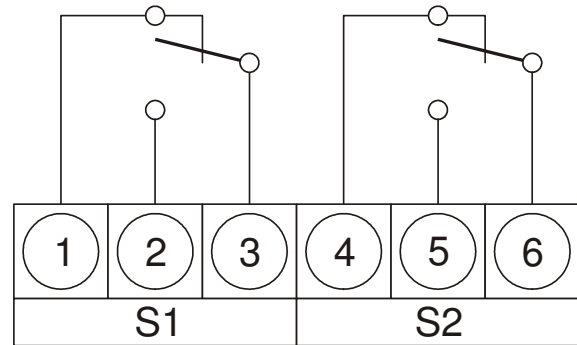

Fig. 4. Wiring ML7421A,B



auxiliary switches  
24 Vac / 5 (3) A

Fig. 5. Accessories

**Honeywell**

Manufactured for and on behalf of the Environmental and Combustion Controls Division of Honeywell Technologies Sàrl, Ecublens, Route du Bois 37, Switzerland by its Authorized Representative:

### Automation and Control Solutions

Honeywell GmbH  
Böblinger Straße 17  
D-71101 Schönaich  
Phone: (49) 7031 63701  
Fax: (49) 7031 637493  
<http://europe.hbc.honeywell.com>

Subject to change without notice. Printed in Germany  
EN0B-0416GE51 R0306

**DIN EN ISO**  
**9001/14001**