



2-Port Seat Valves with Flange, PN 40

VVF61...

- Cast steel GP240GH valve body
- DN 15...150
- k_{vs} 0.19...300 m³/h
- Can be equipped with SKD..., SKB... or SKC... electrohydraulic actuators

Use

For use in district heating, heating, ventilating and air conditioning systems as a control or safety shutoff valve to DIN 32730.

For closed and open circuits (mind cavitation, refer to page 6).

Special silicon-free valve version with type suffix ...5 available.

Type summary

Type	DN	k_{vs} [m ³ /h]	S_v
VVF61.09	15	0.19	>50
VVF61.10		0.3	
VVF61.11		0.45	
VVF61.12		0.7	
VVF61.13		1.2	
VVF61.14		1.9	
VVF61.15		3	
VVF61.23	25	5	>100
VVF61.24		7.5	
VVF61.25		12	
VVF61.39	40	19	>50
VVF61.40		31	
VVF61.49	50	49	>100
VVF61.50		78	
VVF61.65		124	
VVF61.80		200	
VVF61.90		300	
VVF61.91			
VVF61.92			

DN = Nominal size

k_{vs} = Nominal flow rate of cold water (5...30 °C) through the fully open valve (H_{100}) by a differential pressure of 100 kPa (1 bar)

S_v = Rangeability k_{vs} / k_{vr}

k_{vr} = Smallest k_v value, at which the flow characteristic tolerances can still be maintained, by a differential pressure of 100 kPa (1 bar)

Special versions

Type	Type suffix	Description	Examples
VVF61...2	2	Sealing gland with PTFE sleeve for 220...350 °C with thermal insulator, available for $k_{vs} \geq 1.2$ m ³ /h	VVF61.132
VVF61...5	5	Sealing gland with PTFE sleeve, silicon-free version, for temperatures up to 220 °C	VVF61.115

Accessories

Type	Description
ASZ6.5	Electric stem heating element, AC 24 V / 30 W, required for media below 0 °C

Order

When ordering please give quantity, product name and type reference.

Example:

2 two-port valves VVF61.50

Delivery

Valves, actuators and accessories are packed and supplied separately.

The valves are supplied without counter-flanges and without flange gaskets.

Thermal insulator of special version with type suffix 2 is factory-mounted onto the valve on delivery.

This thermal insulator cannot be ordered separately or retrofitted.

Spare parts

PTFE sealing gland
stem-Ø 10 mm

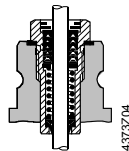

for VVF61...	DN 15 and DN 25	4 284 8829 0
for VVF61...2	DN 15...150	4 284 8829 0
for VVF61...5	DN 15 and DN 25	4 284 9538 0

PTFE sealing gland
stem-Ø 14 mm

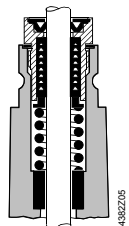

for VVF61...	DN 40...150	4 679 5630 0
for VVF61...5	DN 40...150	4 284 9540 0

Equipment combinations

Valves	H ₁₀₀ [mm]	Actuators					
		SKD... ¹⁾		SKB... ²⁾		SKC... ²⁾	
		Δp_{max}	Δp_s	Δp_{max}	Δp_s	Δp_{max}	Δp_s
[kPa]							
VVF61.09...15	20	1600	4000	1600	4000		
VVF61.23...25			2250				
VVF61.39...40							
VVF61.49...50							
VVF61.65	40					1000	4000
VVF61.80						700	
VVF61.90						450	
VVF61.91						300	
VVF61.92						200	

¹⁾ Usable up to maximum medium temperature of 140 °C

²⁾ Together with actuators SKB... or SKC..., 2-port valves VVF61... are TÜV approved to DIN 32730 and can be used as safety shutoff valves for steam or high-temperature hot water should permissible temperature or pressure limits be exceeded.

H₁₀₀ = Nominal stroke

Δp_{max} = Maximum permissible differential pressure across the valve, valid for the entire actuating range of the motorized valve

Δp_s = Maximum permissible differential pressure at which the motorised valve will close securely against the pressure (close off pressure)

Actuator overview

Type	Actuator type	Operating voltage	Positioning signal	Spring return	Positioning time	Positioning force	Data sheet	
SKD32.50	Electro-hydraulic	AC 230 V	3- position	No	120 s	1000 N	N4561	
SKD32.21				Yes	30 s			
SKD32.51				No	120 s			
SKD82.50		AC 24 V		Yes	30 s			N4563
SKD82.51				No				
SKD60				Yes				
SKD62...				No				
SKB32.50	Electro-hydraulic	AC 230 V	3- position	No	120 s	2800 N	N4564	
SKB32.51				Yes				
SKB82.50				No				
SKB82.51		AC 24 V		Yes			N4566	
SKB60				No				
SKB62...				Yes				
SKC32.60	Electro-hydraulic	AC 230 V	3- position	No	120 s	2800 N	N4564	
SKC32.61				Yes				
SKC82.60				No				
SKC82.61		AC 24 V		Yes			N4566	
SKC60				No				
SKC62...				Yes				

¹⁾ or DC 4...20 mA

Pneumatic actuators

DN 15 and DN 25 can also be used with pneumatic actuators.

For DN 40...150, use of pneumatic actuators is possible only if the direction of flow counters the direction of the arrow (inverted flow direction).

For Δp_{max} and Δp_s the values as listed in the data sheet for the VVF41... (N4340) are valid.

Contact your local office or branch for more information.

Valve cross section

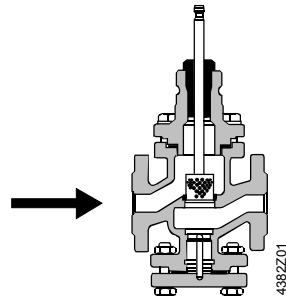

DN 15 and DN 25
closes against pressure

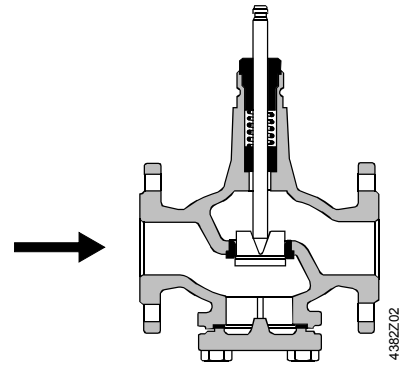

DN 40...150
closes on pressure

Depending on the nominal size, a guided parabolic, perforated or slot plug is used that is directly connected to the valve stem.

The seat is screwed to the valve body with the aid of special gland material.



The two-port seat valve does not become a three-port valve by removing the blank flange!

Thermal insulator

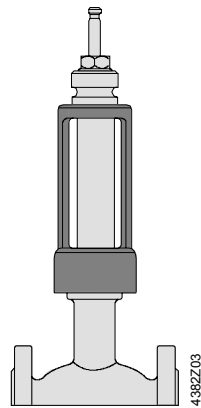

Thermal insulator for special version with type suffix 2, required for media from 220 °C to 350 °C; factory-mounted onto the valve on delivery.

Flow diagram

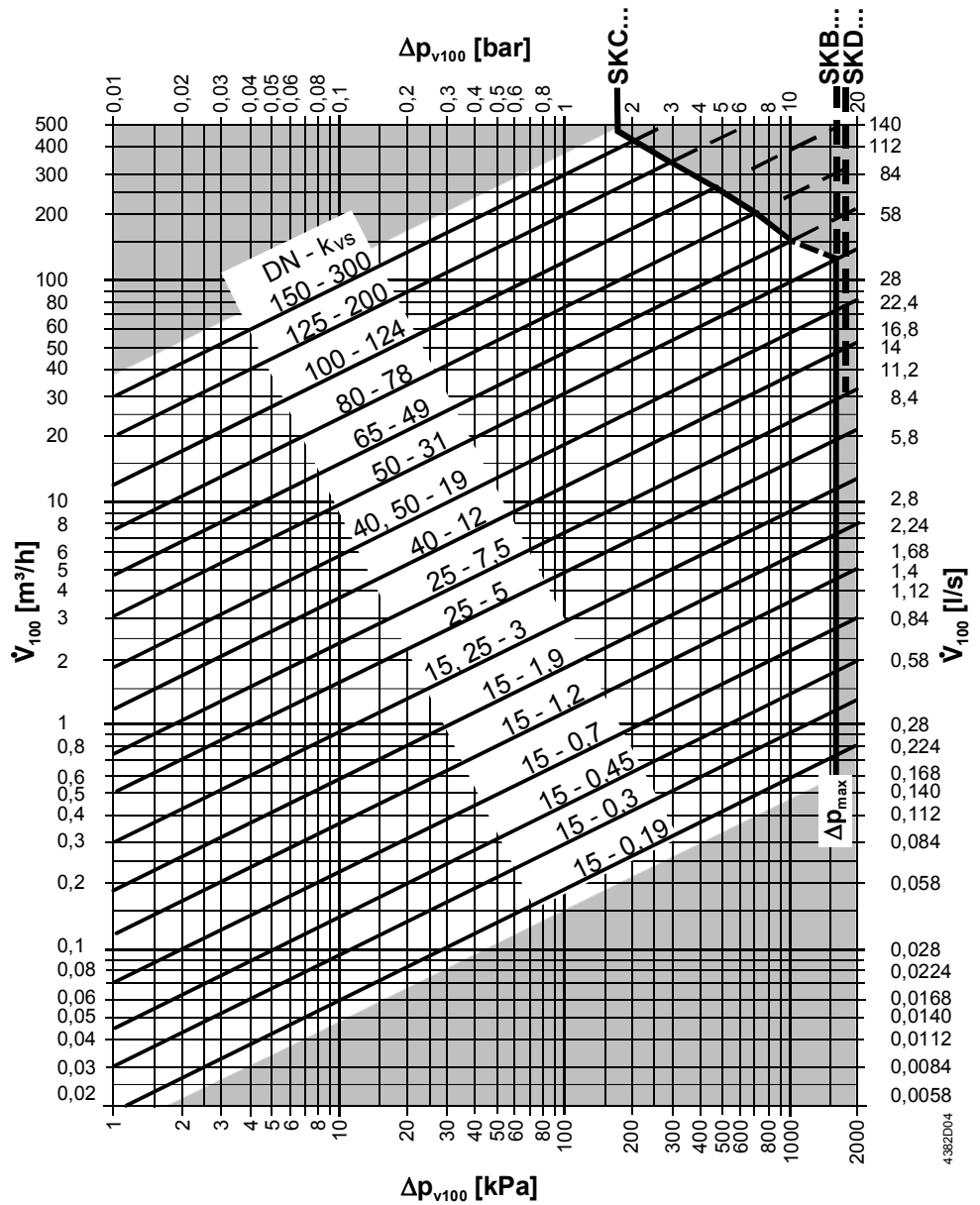

- Δp_{max} = Maximum permissible differential pressure across the valve, valid for the entire actuating range of the motorised valve
- Δp_{v100} = Differential pressure across the fully open valve and the valve's control path by a volume flow \dot{V}_{100}
- \dot{V}_{100} = Volume flow through the fully open valve (H_{100})
- 100 kPa = 1 bar \approx 10 mWC
- 1 m^3/h = 0.278 l/s water at 20 °C

Valve flow characteristic

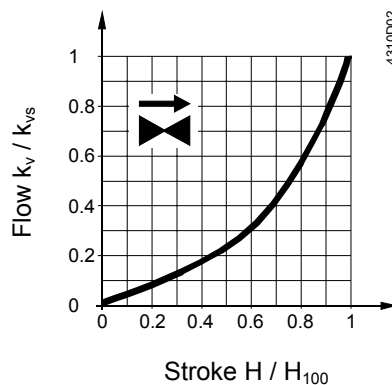

- 0...30 % → linear
- 30...100 % → equal percentage
- $n_{gl} = 3$ as per VDI / VDE 2173

Cavitation

Cavitation accelerates wear on the valve plug and seat, and also results in undesirable noise. Cavitation can be avoided by not exceeding the differential pressure shown in the flow diagram on page 5, and by adhering to the static pressures shown below.

Note on chilled water

To avoid cavitation in chilled water circuits ensure sufficient counter pressure at valve outlet, e.g. by a throttling valve after the heat exchanger. Select the pressure drop across the valve at maximum according to the 80 °C curve in the flow diagram below.

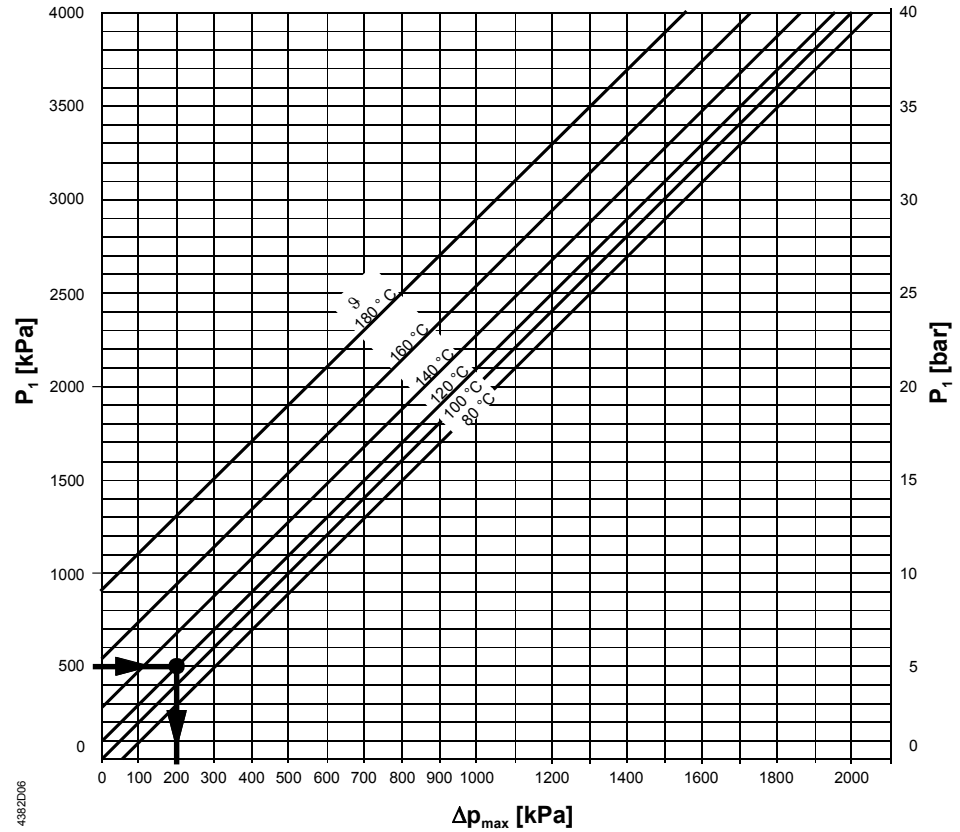

- Δp_{max} = Differential pressure with valve almost closed, at which cavitation can largely be avoided
- p_1 = Static pressure at inlet
- p_3 = Static pressure at outlet
- M = Pump
- ϑ = Water temperature

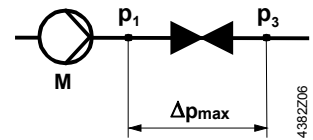

High temperature hot water example:

Pressure p_1 at valve inlet: 500 kPa (5 bar)
 Water temperature: 120 °C

From the diagram above, it will be seen that with the valve almost closed, the maximum permissible differential pressure Δp_{max} is 200 kPa (2 bar).

Chilled water example:

Spring water cooling as an example of avoiding cavitation:

- Chilled water = 12 °C
- p_1 = 500 kPa (5 bar)
- p_4 = 100 kPa (1 bar) (atmospheric pressure)
- Δp_{max} = 300 kPa (3 bar)
- $\Delta p_{3-3'}$ = 20 kPa (0.2 bar)
- Δp_D (throttle) = 80 kPa (0.8 bar)
- $p_{3'}$ = pressure after consumer in kPa

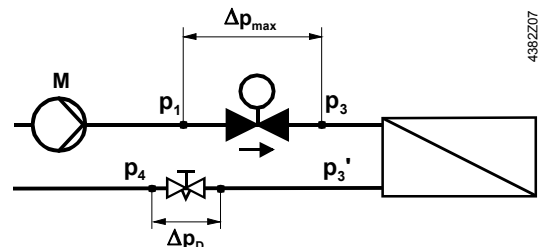

Working pressure and medium temperature
Fluids

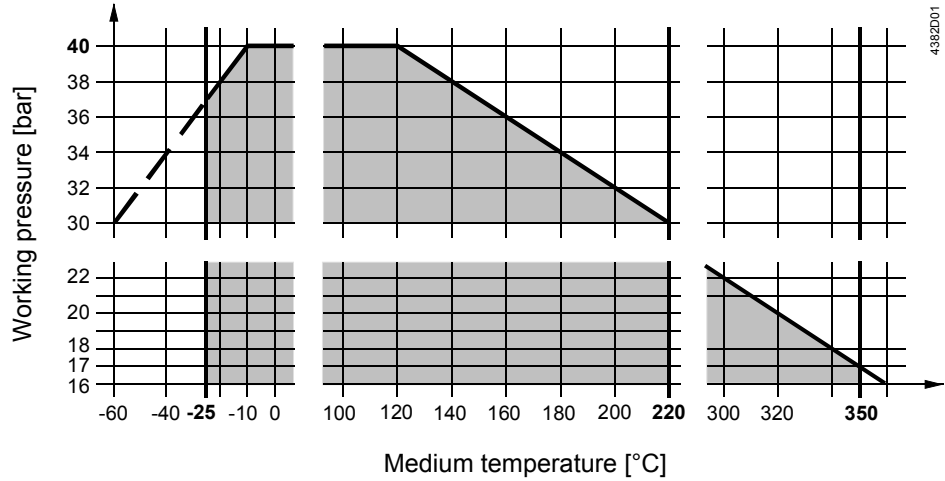

Working pressure staged as per ISO 7268 and EN 1333 at medium temperatures of -25...220 °C (350 °C) as per DIN 4747-1

Saturated steam
Superheated steam

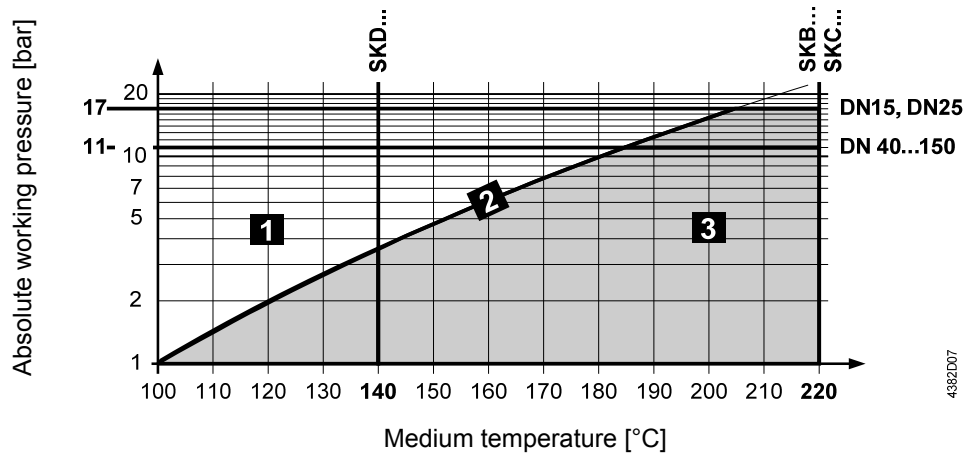

1	wet steam	avoid
2	saturated steam	permissible range of use
3	superheated steam	

Recommendation

For saturated steam and superheated steam the differential pressure Δp_{max} across the valve should be close to the critical pressure ratio.

$$\text{Pressure ratio} = \frac{p_1 - p_3}{p_1} \cdot 100\%$$

p_1 = absolute pressure before valve in kPa
 p_3 = absolute pressure after valve in kPa

Calculation of the k_{vs} value for steam

Subcritical range

$$\frac{p_1 - p_3}{p_1} \cdot 100\% < 42\%$$

Pressure ratio < 42% subcritical

$$k_{vs} = 4.4 \cdot \frac{\dot{m}}{\sqrt{p_3 \cdot (p_1 - p_3)}} \cdot k$$

Supercritical range

$$\frac{p_1 - p_3}{p_1} \cdot 100\% \geq 42\%$$

Pressure ratio \geq 42% supercritical (not recommended)

$$k_{vs} = 8.8 \cdot \frac{\dot{m}}{p_1} \cdot k$$

\dot{m} = steam quantity in kg/h
 k = factor for superheating of steam = $1 + 0.0012 \cdot \Delta T$ ($k = 1$ for saturated steam)
 ΔT = temperature differential in K between saturated steam and superheated steam

Example

given	saturated steam 133.5 °C	saturated steam 133.5 °C
	$p_1 = 300 \text{ kPa (3 bar)}$	$p_1 = 300 \text{ kPa (3 bar)}$
	$\dot{m} = 105 \text{ kg/h}$	$\dot{m} = 105 \text{ kg/h}$
	pressure ratio = 30 %	pressure ratio = 42 % (supercritical permitted)
required	k_{vs} , valve type	k_{vs} , valve type
procedure	$p_3 = p_1 - \frac{30 \cdot p_1}{100}$ $p_3 = 300 - \frac{30 \cdot 300}{100} = 210 \text{ kPa (2.1 bar)}$ $k_{vs} = 4.4 \cdot \frac{105}{\sqrt{210 \cdot (300 - 210)}} \cdot 1 = 3.36 \text{ m}^3 / \text{h}$	$k_{vs} = 8.8 \cdot \frac{105}{300} \cdot 1 = 3.08 \text{ m}^3 / \text{h}$
selected	$k_{vs} = 5 \text{ m}^3/\text{h} \Rightarrow \text{VVF61.24}$	$k_{vs} = 3 \text{ m}^3/\text{h} \Rightarrow \text{VVF61.15 (DN15)}$ or $\Rightarrow \text{VVF61.23 (DN25)}$

Notes

Engineering

We recommend installation in the return pipe, as the temperatures in this pipe are lower for applications in heating systems, which in turn, extends the stem sealing gland's life.



In open circuits the valve plug may seize as the result of scale deposits. In these applications, only the most powerful SKB... or SKC... actuators should be used. Further the valve should be exercised at regular intervals (two to three times per week). A strainer **MUST** be fitted at the valve inlet

Ensure cavitation free flow (refer to page 6).



To ensure the reliability of the valve, we recommend the fitting of a strainer at the valve inlet even in closed circuits.



For media below 0 °C, use the electric ASZ6.5 stem heating element to prevent the valve stem from freezing in the sealing gland. For safety reasons, the stem heating element has been designed for AC 24 V / 30 W operating voltage.

The use of these valves for steam is subject to specific parameters:

Observe diagram for steam on page 7 and «Technical Data» on page 10!

Mounting

Both valve and actuator can easily be assembled at the mounting location. Neither special tools nor adjustments are required.

The thermal insulator is factory-mounted. The actuator is directly mounted on the thermal insulator instead of the valve

The valve is supplied with Mounting Instructions 74 319 0509 0.

Orientation

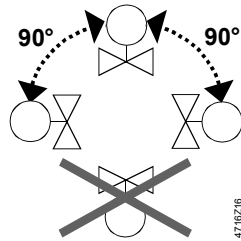

Direction of flow

When mounting, pay attention to the valve's flow direction symbol →.

Commissioning



Commission the valve only if the actuator has been mounted correctly.

Valve stem retracts: valve opens = increasing flow
Valve stem extends: valve closes = decreasing flow

Maintenance

Warning



VVF61... valves require no maintenance.

When doing service work on the valve / actuator:

- Deactivate the pump and turn off the power supply
- Close the shutoff valves
- Fully reduce the pressure in the piping system and allow pipes to completely cool down

If necessary, disconnect the electrical wires.

Before putting the valve into operation again, make certain the actuator is correctly fitted.

Stem sealing gland

The glands can be exchanged without removing the valve, provided the pipes are depressurized and cooled off and the stem surface is unharmed.

If the stem is damaged in the gland range, replace the entire stem-plug-unit.

Contact your local office or branch.

Disposal



Before disposal the valve must be dismantled and separated into its various constituent materials.

Legislation may demand special handling of certain components, or it may be sensible from an ecological point of view.

Current local legislation must be observed.

Warranty

The technical data given for these applications is valid only in conjunction with the Siemens actuators as detailed under «Equipment combinations».

All terms of the warranty will be invalidated by the use of actuators from other manufacturers.

Technical data

Functional data	PN class	PN 40 to EN 1333
	Working pressure	to DIN 4747-1 within the permissible medium temperature range according to the diagram on page 7
	Flow characteristic	<ul style="list-style-type: none"> • 0...30 % • 30...100 % <ul style="list-style-type: none"> • linear • equal percentage; $n_{gl} = 3$ to VDI / VDE 2173
	Leakage rate	0...0.02 % of k_{vs} value to DIN EN 1349
	Permissible media: water	cooling water, chilled water, low temperature hot water, high temperature hot water, water with anti-freeze; recommendation: water treatment to VDI 2035
	brine	
	steam	saturated steam, super-heated steam; dryness at inlet minimum 0.98
	thermo oils	
	Medium temperature water, brine ¹⁾ steam	max. 220 °C (350 °C) -25...220 °C ≤ 220 °C DN 15...25 ≤ 1700 kPa (17 bar) abs ≤ 220 °C DN 40...150 ≤ 1100 kPa (11 bar) abs permissible temperature and pressure range according to the diagram on page 7
	thermo oils ²⁾	≤ 350 °C
Industry standards	Rangeability S_v	DN 15...40: > 50 (VVF61.25: >100) DN 50...150: > 100 (VVF61.49: >50)
	Nominal stroke	DN 15...50: 20 mm DN 65...150: 40 mm
	Pressure Equipment Directive	PED 97/23/EC
	Pressure Accessories	as per article 1, section 2.1.4
Materials	Fluid group 2:	<ul style="list-style-type: none"> • DN 15...25 • DN 40...80 • DN 100...150 <ul style="list-style-type: none"> • without CE-marking as per article 3, section 3 (sound engineering practice) • category I, with CE-marking • category II, with CE-marking, test authority number 0036
	Valve body	cast steel GP240GH
	Stem	stainless steel
	Plug, seat	stainless steel
	Sealing gland ³⁾	stainless steel
Dimensions / Weight	Gland materials	PTFE sleeves
	Refer to «Dimensions»	
	Flange connections	to ISO 7005

¹⁾ Electric stem heating element ASZ6.5 required for media below 0 °C.

²⁾ For 220...350 °C with thermal insulator, type suffix 2, use electrohydraulic SKB... or SKC...actuators.

³⁾ Silicon-free version with type suffix 5

Dimensions

Dimensions in mm

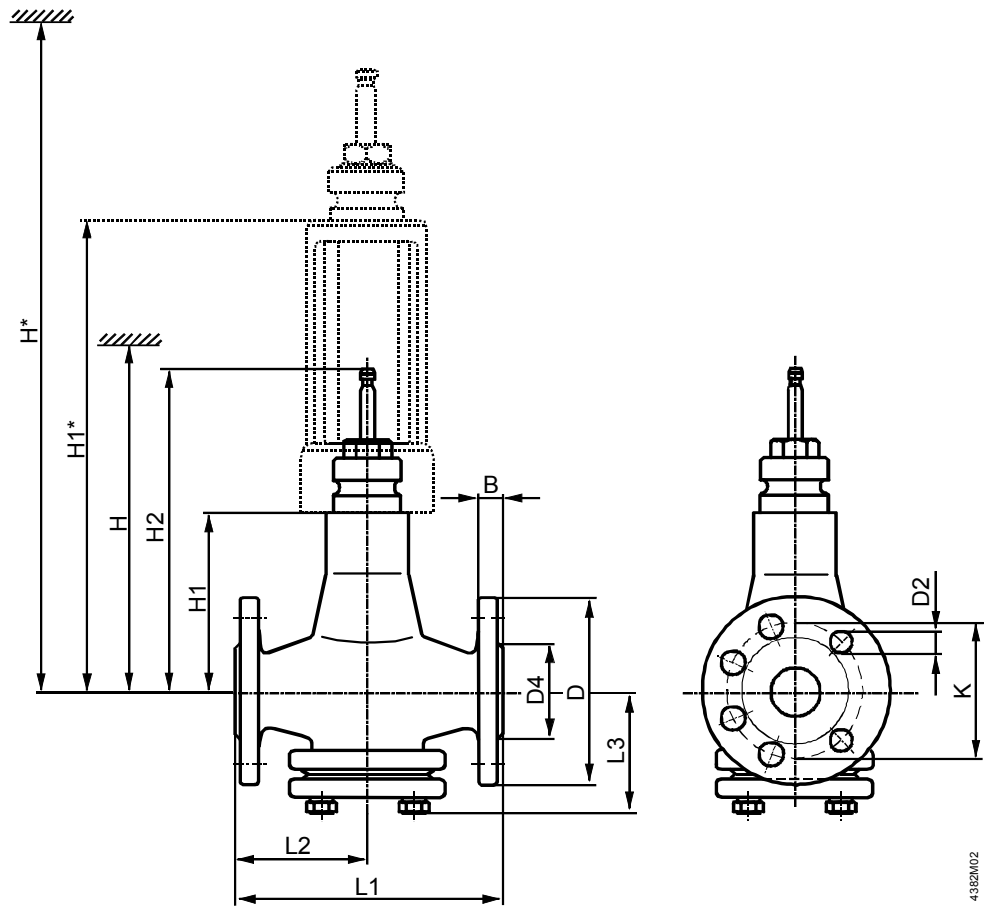

4382M02

DN	B	D Ø	D2 Ø	D4 Ø	K	L1	L2	L3	H1	H2	H			H1*	H*			kg	
											SKD...	SKB...	SKC...		SKD...	SKB...	SKC...	VVF61...	VVF61...2
15	16	95	14 (4x)	46	65	130	65	90	96	192.5	>596	>671		276	>776	>851		7.4	10.7
25	18	115		67	85	160	80	107	111	207.5	>611	>686		291	>791	>866		10	13.3
40	20	150	18 (4x)	84	110	200	100	102	136	232.5	>636	>711		316	>816	>891		16	19.5
50	20	165		99	125	230	115	107										18	21.5
65	22	185	18 (8x)	118	145	290	145	138	162	278.5			>737	342			>917	29	32.5
80	24	200		132	160	310	155	150	170	286.5			>745	350			>925	35	38.5
100	26	235	22 (8x)	156	190	350	175	173	180	296.5			>755	360			>935	52	55.5
125	26	270	26 (8x)	184	220	400	200	195	200	316.5			>775	380			>955	74.5	78
150	28	300		211	250	480	240	219	225	341.5	>800	405	>980	110	113.5				

DN = Nominal size

H = Total actuator height plus minimum distance to the wall or the ceiling for mounting, connection, operation, maintenance etc.

H1 = Dimension from the pipe centre to install the actuator (upper edge)

H2 = Valve in the «Closed» position means that the valve stem is fully extended

