

Wiring diagrams: Open/Close actuators—parallel connection possible, please note the performance data.

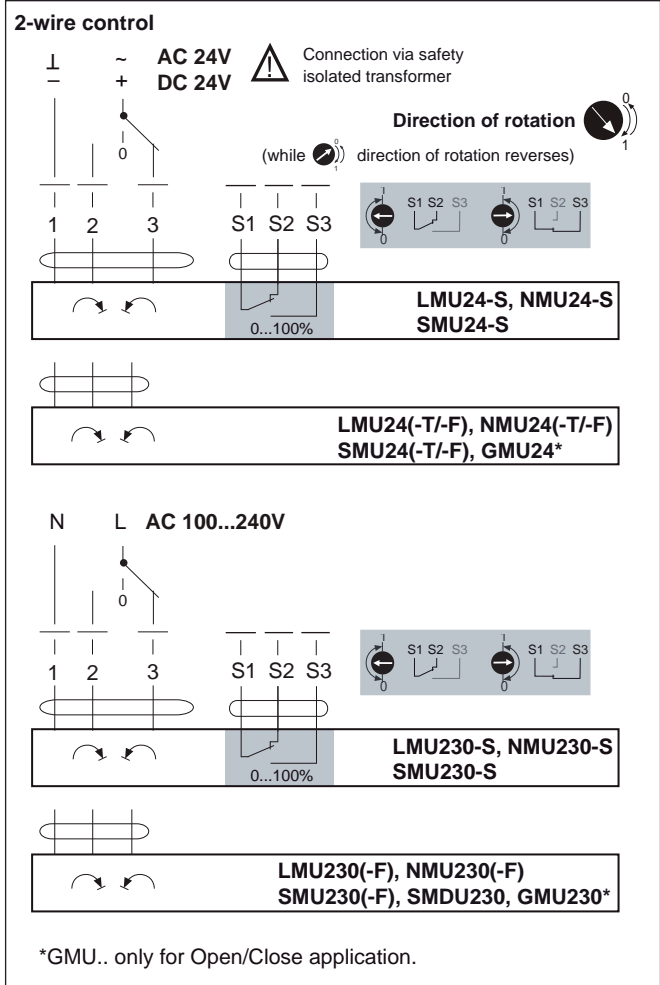

Wiring diagram: Modulating actuators—parallel connection possible, please note the performance data.

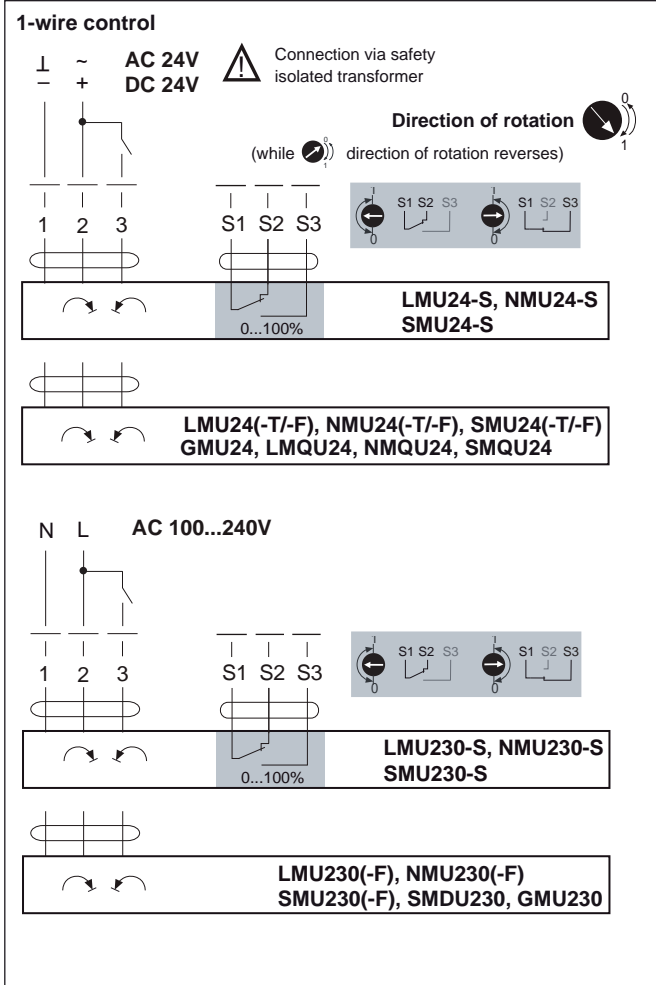
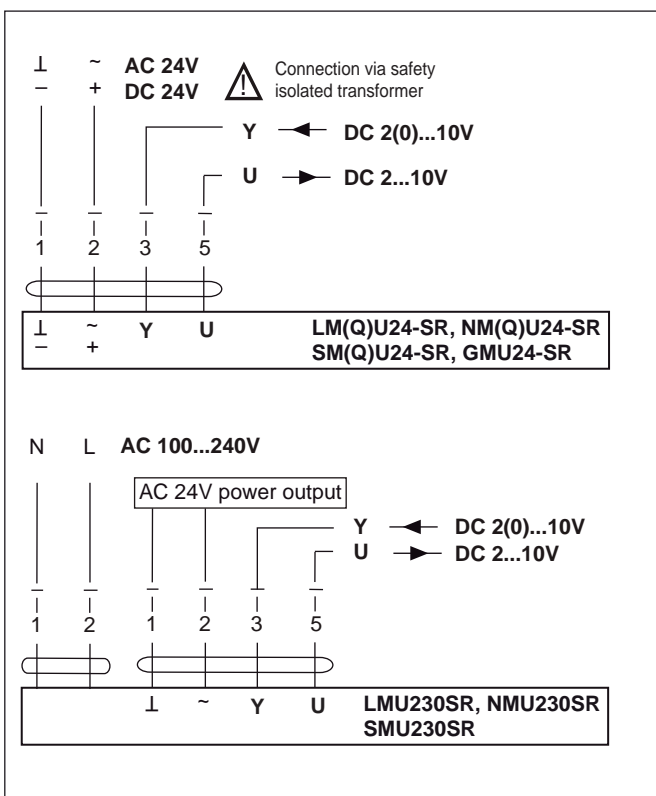

Position - signal voltage

