



## Controls

saia-burgess

Smart solutions for comfort and safety

# SAIA®S-Bus communication for the PCD

The universal protocol for all communications tasks

### SAIA®S-Bus – more than just a bus system

- SAIA®S-Bus is the system protocol of SAIA® controllers and included as standard in every CPU. It can be used on a variety of physical transmission media (RS 232, RS 485, RS 422, TTY/current loop 20mA, Ethernet-TCP/IP, modem, LWL, ...).
- Simultaneous use at several interfaces is supported.
- Optimized for data exchange and programming. Access with the PG5 tool for programming, debugging and commissioning is equally supported, as is the exchange of data between PCD controllers.
- Economical realization of master/slave networks with the simple RS 485 two-wire line.
- Multimaster communication for event-controlled data transfer in large network structures with Ethernet-TCP/IP.
- Costs saved on the commissioning and maintenance of equipment and machines when S-Bus is used via telecommunications networks (analogue, ISDN, GSM).

### Features of the SAIA®S-Bus protocol

- Proven performance in countless applications for data exchange between PCD controllers.
- Ease of handling during installation, commissioning and programming thanks to simple IL instructions, convenient FUPLA FBoxes, extensive diagnostic capabilities and the powerful PG5 programming tool.
- High reliability of transmission due to CRC-16 error recognition.
- Simple, efficient and with a high level throughput due to low protocol overheads and binary protocol type.
- Unlimited addressing: Up to 254 stations can be addressed in a local S-Bus network. Via Ethernet-TCP/IP multiples of 254 stations can be addressed.
- OPC server for SAIA®S-Bus so that SAIA®PCD controllers can easily be linked to visual display and management systems.

# Very powerful, universal concept

## Monitoring, visual display, programming and commissioning

with S-Bus across serial ports, Ethernet-TCP/IP or telecommunications networks



ETHERNET-TCP/IP

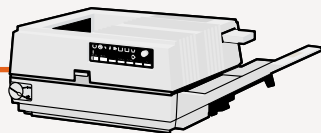
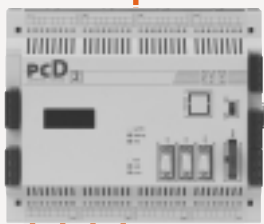

EXTERNAL DEVICES

## Point-to-point communication

with S-Bus via standard RS 232, RS 422/RS 485 serial ports, TTY/20 mA current loop or via modem



## Simple, efficient master/slave networks

with S-Bus and RS485 interfaces

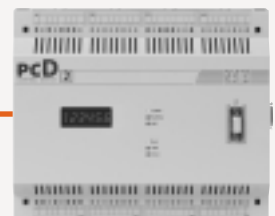

**S-Bus communication via modem and telecommunications networks**

for telecontrol, telemonitoring, telediagnosis and remote programming of equipment or machines

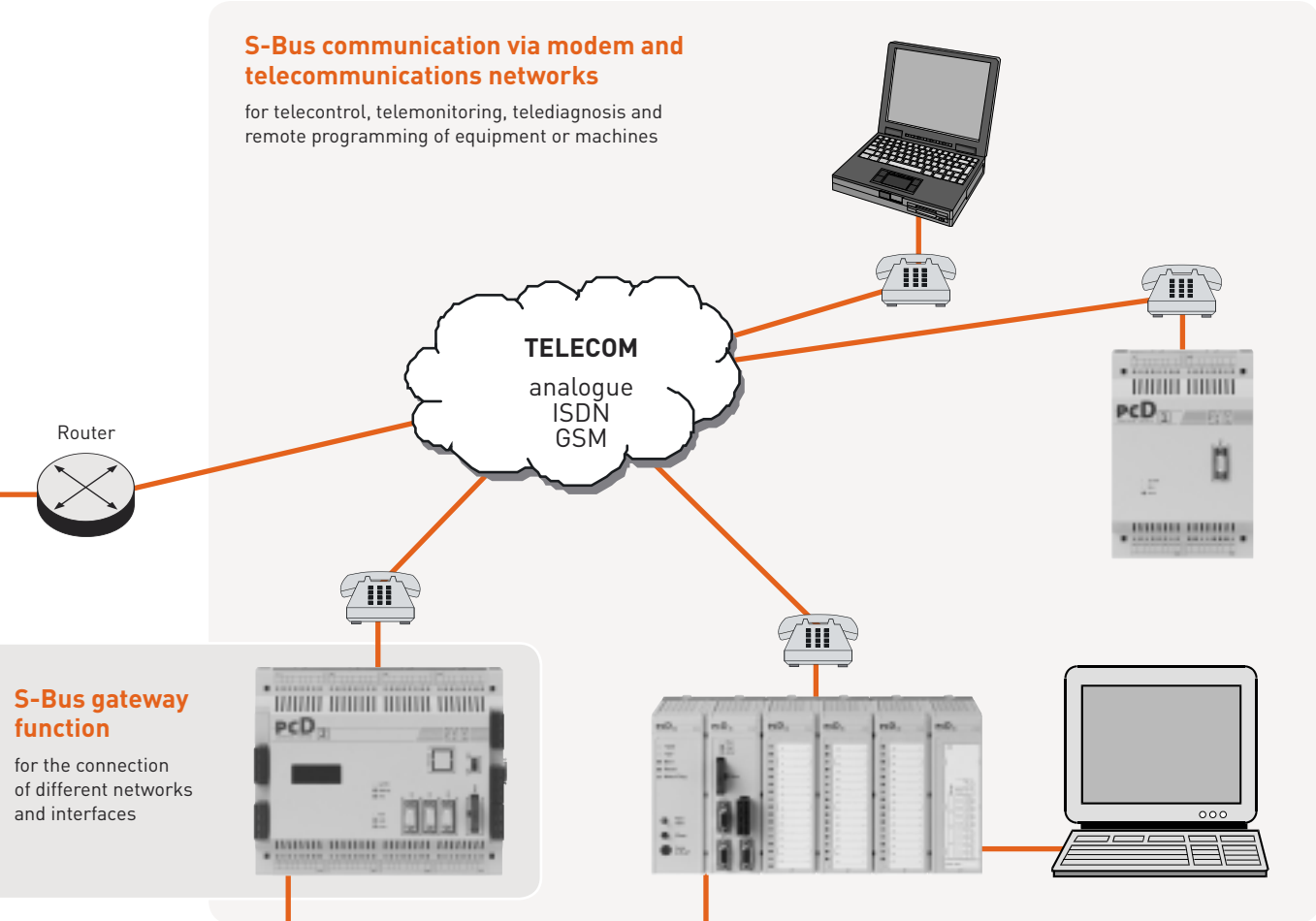

**S-Bus gateway function**  
for the connection of different networks and interfaces

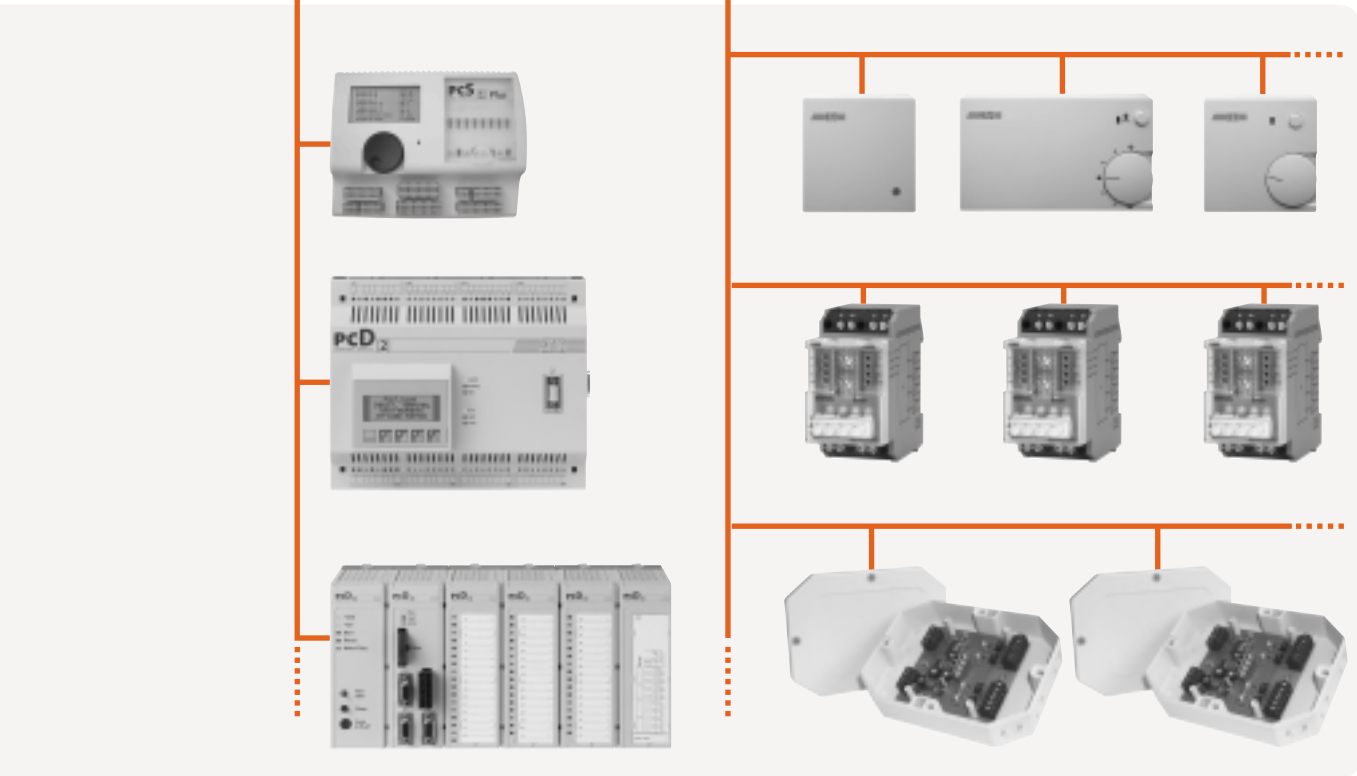

# SAIA®S-Bus protocol

## Principles of the S-Bus protocol

The S-Bus protocol is the system protocol of SAIA®PCD controllers. It is a simple but very efficient protocol that all PCD CPUs will support. It has been specially designed for the exchange of data with PCD controllers and for programming them with the PG5 programming tool. The protocol is distinguished by the following features in particular:

- Simple and efficient due to low protocol overheads.
- Master/slave communication in half-duplex operation.
- With the simple RS485 two-wire line, it can be used to realize a very economical master/slave network.
- Can be used on almost all physical transmission media, such as serial ports (RS232, RS422/RS485, TTY/20mA current loop), Ethernet-TCP/IP, LWL, modem, ...
- Good reliability of transmission guaranteed by CRC 16 error recognition.
- Addressing of up to 254 stations in a local S-Bus network. With Ethernet-TCP/IP multiples of 254 stations can be operated.
- Supports broadcast telegrams.
- The protocol can run simultaneously on several interfaces in parallel.
- The protocol supports the reading and writing of all PCD data (inputs, outputs, flags, registers, timers, counters, text, data blocks, clock, etc.)
- On serial ports all baud rates are supported up to max. 38.4kBd. With Ethernet-TCP/IP, 10 and 100 MBd are supported respectively.
- S-Bus communication can very easily be programmed by the user thanks to optimized IL instructions and convenient FUPLA FBoxes.

## Services and functions supported

The S-Bus protocol fundamentally supports two distinct application service levels.

### Level 1 – Data transfer service

This service supports the reduced S-Bus protocol for data transfer (write and read) between PCD controllers, reading status information and triggering special functions. It is also used for the exchange of data between PCD controllers and management systems.

**PCD data:** inputs, outputs, flags, registers, timers, counters, data blocks and hardware clock

**Status information:** CPU number, type and status, firmware version, S-Bus station number

**Special functions:** forced execution of special program blocks (XOB17, 18, 19) in a slave station. This enables the user to trigger interrupts in a partner station via a communications interface.

Level 1 service is assigned in the user program with IL instructions or FUPLA FBoxes.

### Level 2 – Programming and commissioning service

This service supports the entire S-Bus protocol and is used by the programming tool for programming, debugging and commissioning PCD stations. All PG5 functions can be used with it (e.g. program download, run/stop, conditional run, diagnosis, etc., etc.) across all the interfaces shown in the diagram below, including the telecommunications network via modem .

The PG5 programming tool is used to configure this service on PCD controllers. Each controller can have one interface configured for level 2 service. Configuration for level 2 service automatically includes support for all data transfer functions of level 1 service.

Access to a PCD controller with level 2 service can be password protected.

## S-Bus in the ISO/OSI communications model

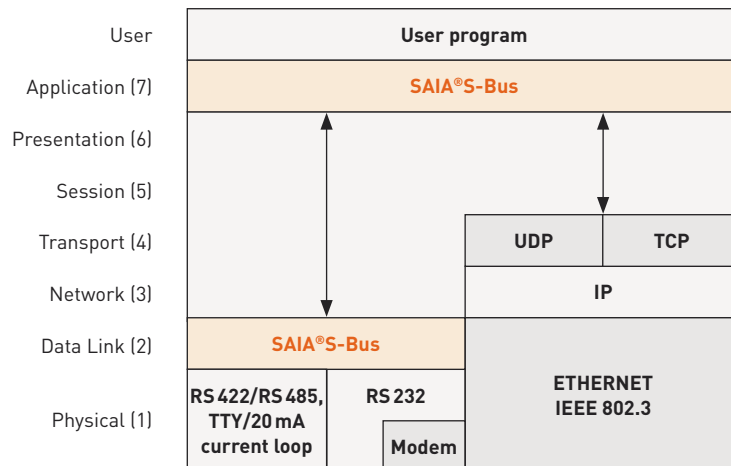

## SAIA® S-Bus in point-to-point or in RS 485 network

### Point-to-point communication

In point-to-point connections, the S-Bus protocol can be used on all available serial ports.

#### Available serial ports

- RS 232, RS 422, RS 485, TTY/20mA current loop
- Use via modem also possible in connection with RS232.
- S-Bus can also be used on several interfaces at once.

#### Services and functions supported

- Level 1 service for data transfer
- Level 2 service for programming and commissioning

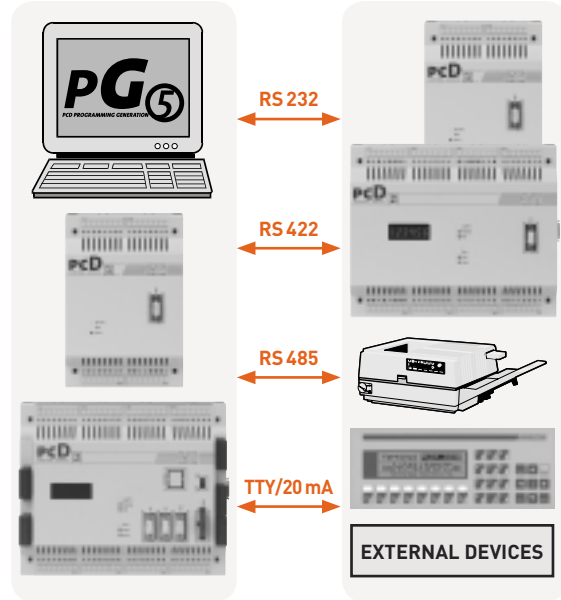

### RS 485 master/slave network

A master/slave network can very simply and economically be constructed using the RS 485 interface (also available in an electrically isolated version) that is present or can be fitted in any SAIA®PCD.

#### Features of the master/slave network

- On the network, 1 master station can be run with up to 254 slave stations in segments of 32 stations each.
- In association with the gateway function, up to 4 master stations (inc. master station) have access to the S-Bus network.

- Maximum distance per segment or between repeaters: 1200 m.
- Segments are connected to each other with PCD7.T100 repeaters.

#### Services and functions supported

- Level 1 service for data transfer
- Level 2 service for programming and commissioning

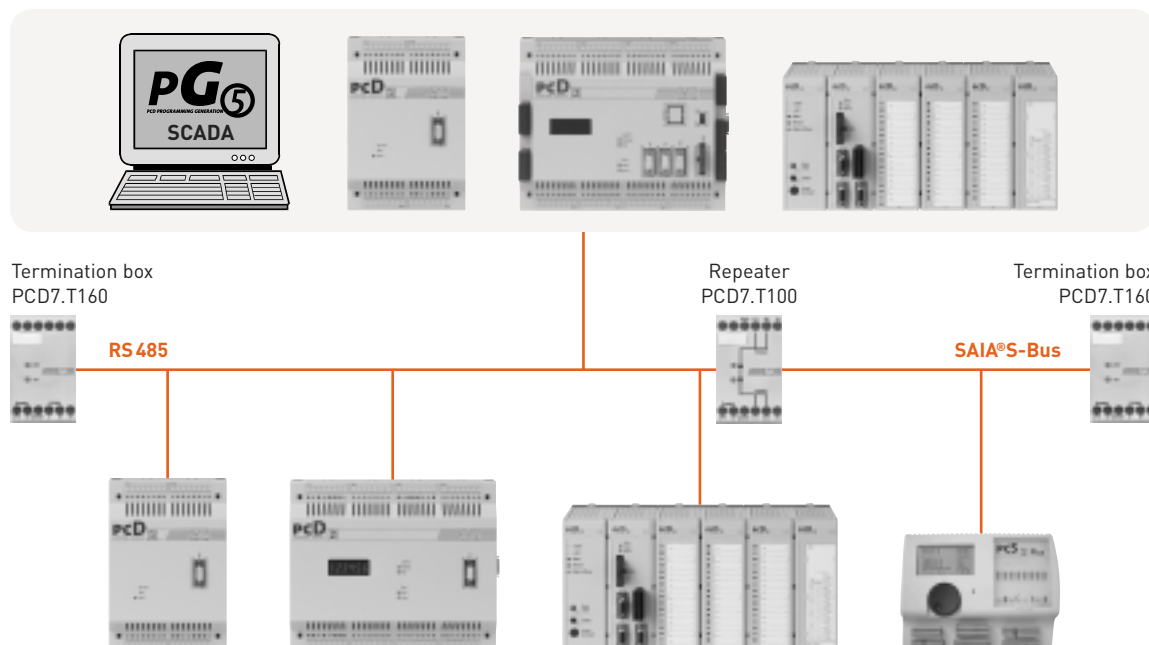

## SAIA®S-Bus across telecommunications networks

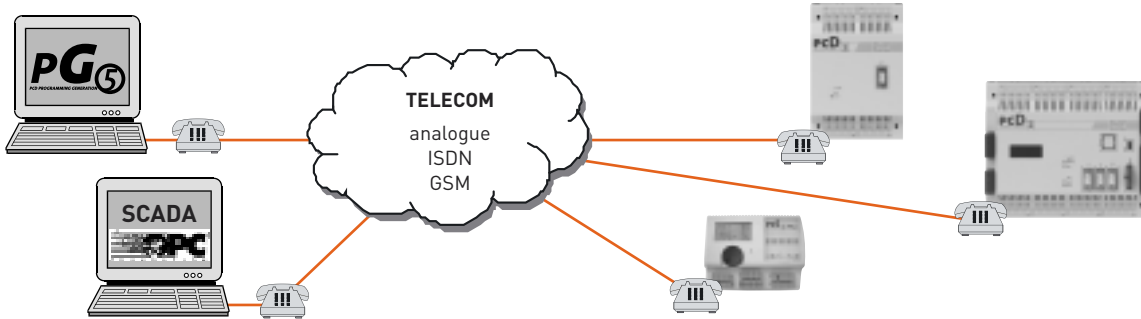

### Telecommunication – the modern solution that overcomes distances and saves costs

By using telecommunications technologies, it is possible not only to economize on operating and maintenance costs, but also to increase the safety, availability and profitability of equipment or machines at the same time. This is achieved by:

- Remote support during commissioning.
- Event or time-controlled information and alarms via the telecommunications network.
- Fault elimination through remote diagnosis.
- Process optimisation through software updates and/or the updating of process parameters.
- Preventive, efficient servicing by qualified professionals leading to low maintenance costs.
- Remote support for users, close to operations, directly on-screen.

### Modem modules for connection to the public telecommunications network

Modem modules have been specially produced for the PCD1, PCD2 and PCS that offer connection to the public telecommunications network. They are the PCD2.T813 33.6 kbs analogue modem and the PCD2.T850 ISDN-TA.



These modem modules, which can be built into the controller, are an easy, economical way of connecting PCD systems to the telecommunications network. For details see Technical Information 26/335.

Connection is also supported of standard commercial modems for the analogue, digital (ISDN) or radio (GSM) telecommunications networks.

### Telecommunication supported by all PCD CPUs and the PG5 programming tool

S-Bus supports communication via modem and telecommunications networks. Modem connection is already included in the PCD's operating system.

Services and functions supported:

- Level 1 service for data transfer
- Level 2 service for programming and commissioning

With level 1 service, data can be exchanged between PCD controllers or between PCD controllers and a management system via the telephone network. To transfer data, several interfaces can be assigned in the user program for modem operation. The PG5 provides an efficient modem library for programming modem communications simply and conveniently. For details see Technical Information 26/368.

With level 2 service, the PG5 programming tool also has access via the telephone network to PCD controllers. It is therefore also possible to use all the PG5's functions via the modem and telecommunications networks. Each PCD controller can have one interface configured for programming via modem.

### Telecommunication via private fixed connections, leased lines, or via radio data networks

S-Bus also supports the use of commercial modems for operation through leased lines and radio data networks. These types of modem can be used to produce multipoint networks with fixed lines or radio data to bridge large distances. The modems are connected via an RS 232 interface to the PCD. Level 1 and level 2 services are supported for data transfer and programming.

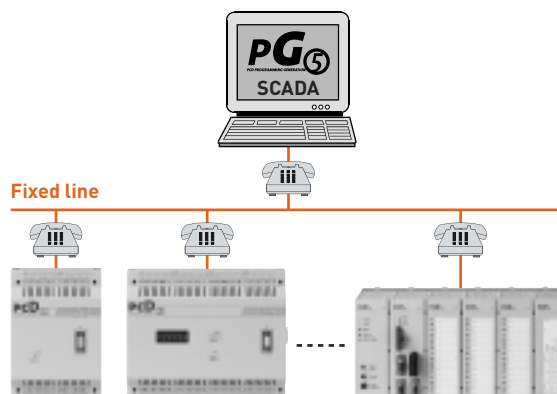

## SAIA®S-Bus via Ethernet-TCP/IP

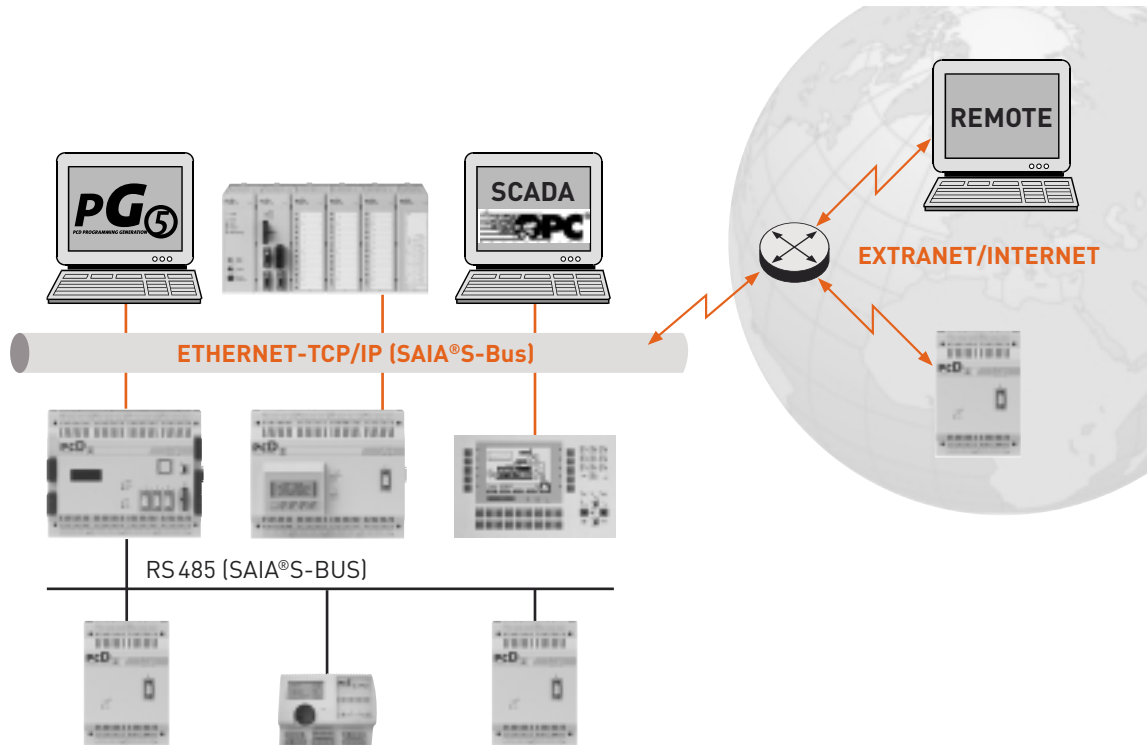

### Substantial advantages from the use of S-Bus via Ethernet-TCP/IP

- Time saved in project planning, programming, commissioning and maintenance via Ethernet-TCP/IP, due to
  - central access with PG5 to all SAIA®PCDs in the Ethernet,
  - convenient programming with PG5 editors
  - the same user programs for all PCD systems
  - fast program download via Ethernet
- S-Bus with multimaster functionality via Ethernet-TCP/IP allows:
  - event-controlled data transfer in real time
  - reduced loading of network, even for very large installations
  - connection of several programming devices with the PG5 to the same network
  - connection of several SCADA systems with access to the same PCD systems
- With the gateway functionality of SAIA®S-Bus, several S-Bus subnets can be integrated within one Ethernet. As a result, the maximum number of S-Bus stations is no longer limited to 254, instead a multiple of that number can operate in one composite network.
- Universal connectivity due to the OPC server (OLE for process control) and DLL libraries for Windows.

### Features and functions of PCD7.F65.. Ethernet-modules

- Intelligent co-processor module with fast dual-port RAM interface to CPU. The module is plugged onto the large socket B.
- Ethernet-connection:
  - Standard IEEE 802.3
  - Connection 10 Base-T/100 Base-TX, RJ45 connector
  - Speed 10/100 MBit/s (autosensing)
- Transport protocol: UDP/IP
- Applications protocol: S-Bus
- Services and functions supported with S-Bus:
  - Level 1 service for data transfer between PCD systems or between PCDs and higher ranking management systems. Communication is programmed with the familiar S-Bus IL instructions, or graphically with convenient FUPLA FBoxes.
  - Level 2 service for programming and commissioning with the PG5. This service is configured on the PCD with the PG5.
- One PCD7.F65.. module is used per CPU.
- For details see Technical Information 26/356.

## SAIA®S-Bus gateway function

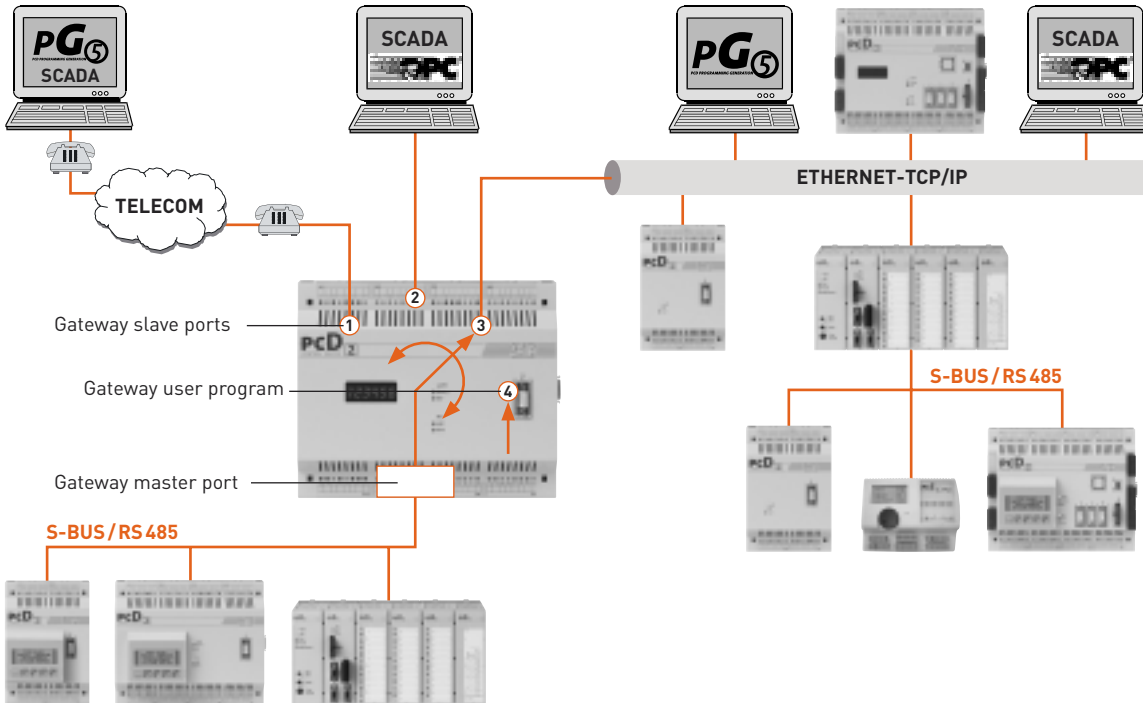

### Advantages of S-Bus gateway

- Allows network junctions and interface adjustments to be realized.
- Supports the connection of 3 additional external master devices. At the same time, one also has access from the user program in the gateway station to all slave stations on the subordinate S-Bus network.
- In addition to the PCD master station, the PG5 programming tool and/or a management system also have access to slave stations on the subordinate S-Bus network. This access can also be via modem and telecommunications networks.
- Universal, direct access by master stations to all slave stations in the RS485 S-Bus network. Master stations on the Ethernet-all have direct access to slave stations in the subordinate S-Bus network.

### Gateway function

An S-Bus network basically consists of one master and a number of slaves. This master can, in addition to its master function, also take on that of a gateway. Three further master devices can be connected to the master station's unused serial ports. In this way, the gateway master regulates access by other masters to the slaves. All PCD systems can take on this gateway function. Via an Ethernet-connection, any number of external master stations can have access to slave stations on the subordinate S-Bus network.

One gateway slave interface can be used with a level 2 service for programming and commissioning while the other slave interfaces can be used with a level 1 service for data transfer.



## OPC server for SAIA®S-Bus

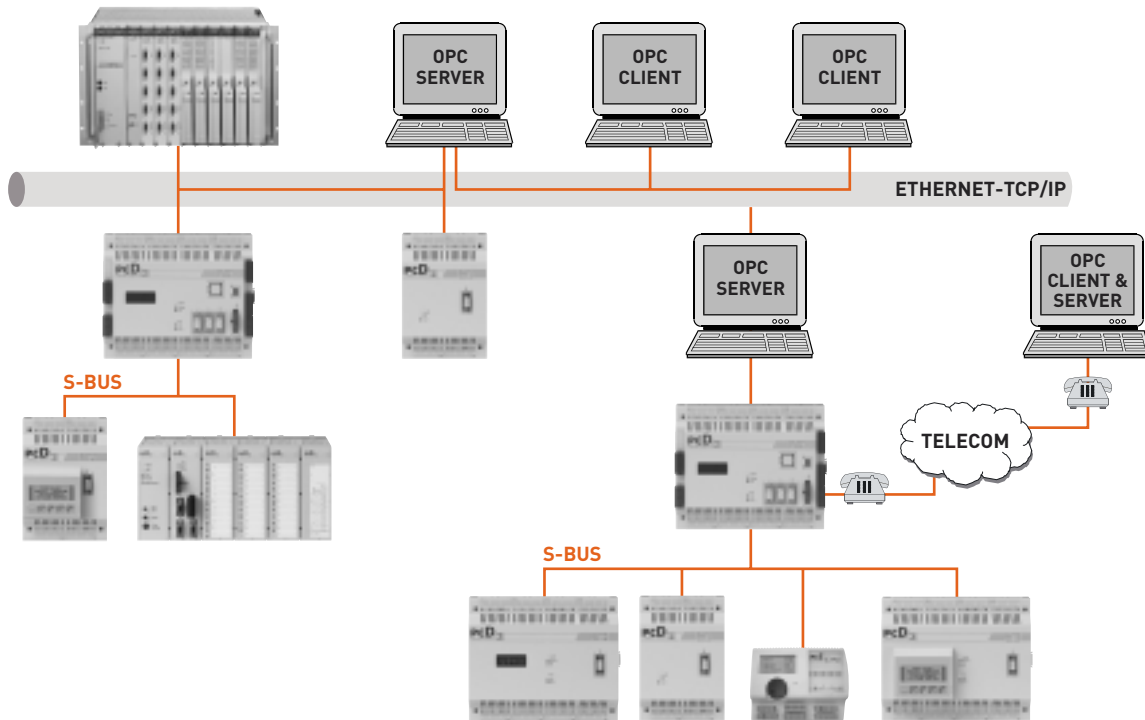

### OPC server ...

- **Standardized OPC interface:** Specialized knowledge of vendor-specific protocols is no longer required. This results in significantly lower development, commissioning and maintenance costs.
- **OPC project:** All OPC data in networked controllers is united in a single project. This results in clearly structured data and simplifies the appropriate definition of data points.
- **Import of PLC variables:** Once symbols or data points for a PLC program have been defined with the PG3/PG4 or PG5 programming tools, they can be adopted and used by the OPC server without modification.
- **Communication by every route:** Communication between the OPC server and the SAIA®PCD can be via RS 232, RS 485, modem, Ethernet-TCP/IP or dual-port RAM (PC/104). Numerous OPC clients can access the OPC server simultaneously via several PC ports.

### Technical data

OPC data access standards supported  
PC operating systems supported  
Protocols supported  
S-Bus services supported  
PLC data capable of representation  
Data formats for import functions

1.01a, 2.04  
MS Windows NT 4.0 SP4, MS Windows 95, MS Windows 98, Windows 2000  
S-Bus via RS232, RS422, RS485, modem (RS232) and Ethernet-UDP/IP  
Level 1 service for data transfer  
Inputs, outputs, flags, registers, data blocks, timers, counters, real-time clock, display register, firmware version  
\*.src (PG3, PG4), \*.pcd (PG4, PG5), \*.sy5 (PG5)  
\*.csv (coma separated values; e.g. from Excel)

### ... in combination with SAIA®S-Bus

- **OPC server/SAIA®PCD:** Visual display and management systems with an OPC-client interface can be connected to any SAIA®PCD controller. This enables every OPC client, via the OPC server, to read data from or write it to the PCD.
- **S-Bus protocol:** This protocol is integral to every SAIA®PCD. Simple, reliable and efficient, it supports point-to-point and master-slave communication between the OPC server and the controller. The OPC server supports all S-Bus protocols, including the new protocol on Ethernet-TCP/IP.
- **Master-slave network:** Up to 3 external OPC servers have simultaneous access to all SAIA®PCD controllers in a network and their data.
- **PG5 programming tool:** Efficient programming and diagnosis for all SAIA®PCDs in a network.
- **For details see Technical Information 26/357.**

# Configuration and programming of SAIA®-S-Bus communication

In the PCD, S-Bus interfaces are either configured with the PG5 programming tool or assigned via the user program.

## Configuration of an S-Bus interface

In the PG5 hardware configurator, the S-Bus station number and port number for level 2 service are defined as settings and then downloaded for configuration in the PCD. Each PCD CPU can have one port configured with level 2 service.

## Programming S-Bus communication

In the user program, S-Bus communication is programmed with simple IL instructions or the convenient FUPLA FBoxes.

### IL instructions

The following is a selection of the main IL instructions:

#### SASI Assign Serial Interface

Initializes the interface as master or slave with the appropriate communications parameters, such as baud rate, diagnostic elements, etc.

#### STXM Serial Transmit Data

Transmits PCD data to a partner station

#### SRXM Serial Receive Data

Receives PCD data from a partner station

### FUPLA FBoxes

The following represents a selection of the main FBoxes. For details see Technical Information 26/367.

#### SASI FBoxes for interface initialization

The SASI FBox initializes an interface for the relevant communication. As a rule, it must stand at the beginning of the program (before any send/receive FBoxes).



**SASI SBus Master**  
Initializes a serial interface as master of an S-Bus network. The PCD is now able to read and write slave elements.



**SASI SBus Slave**  
Initializes a serial interface as a slave in a SAIA®-S-Bus network. The master station can now read and write elements.

#### Receive and send FBoxes for data transfer

These FBoxes read or write elements such as flags, timers, counters registers, BD elements, inputs and outputs from or to an S-Bus slave.



Receive Binary  
Receive Integer  
Receive Float  
Receive Data-Block



Transmit Binary  
Transmit Integer  
Transmit Float  
Transmit Data-Block



## RS 485 bus components and remote I/O modules

### RS 485 bus components

Network communication saves costly wiring and offers a high level of comfort. The foundations of a perfectly functioning network in an industrial environment are laid with a carefully and professionally installed physical bus line.

Bus components for SAIA®S-Bus and PROFIBUS networks assist in this. They produce faultless idle signals, terminate bus lines perfectly and, with electrical isolation, eliminate the noise effects of potential differences.

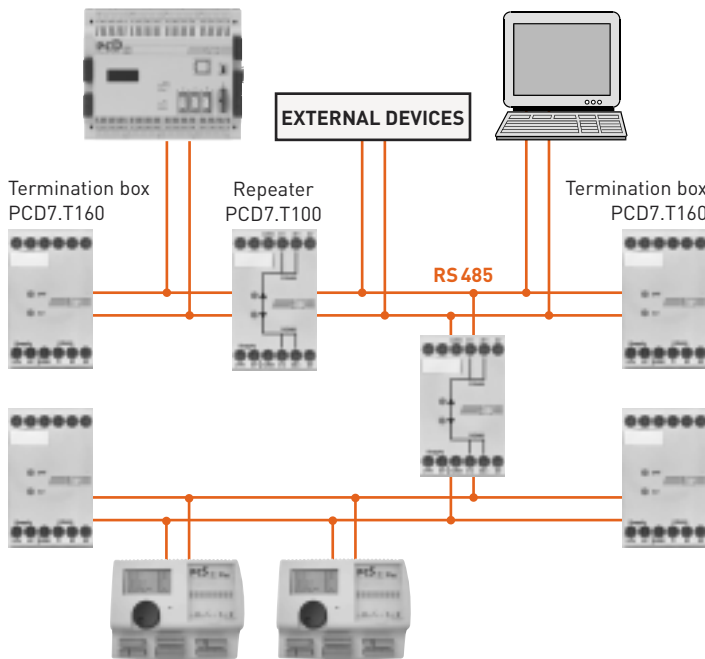

### Remote input/output modules for SAIA®S-Bus

These modules allow remote connection of digital and analogue signals to the SAIA®S-Bus via an RS 485 two-wire line. Modules are available in two versions.

- RAIL: Switch cabinet version for mounting on 35 mm top-hat rail and manual control with acknowledgement via the bus.
- SAFE: Protected version for surface mounting, protection class IP 65 and manual control.

For details see Technical Information 26/339.

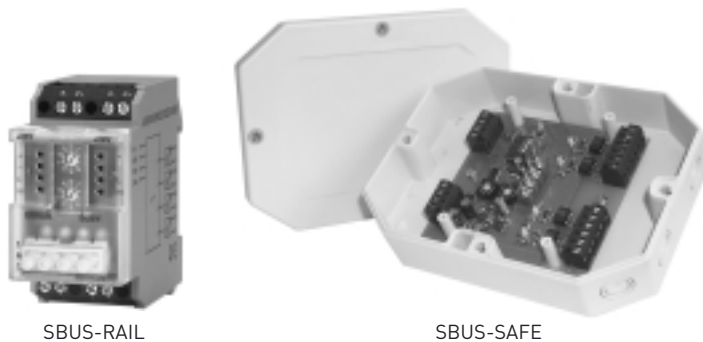

SBUS-RAIL

SBUS-SAFE

#### Termination box PCD7.T160

This is used for electrical isolation between the supply and the RS 485 network, including idle signal bias voltage and the optimum termination of bus lines. Use in range up to 12 MBit/s.

Order reference: **PCD7.T160**

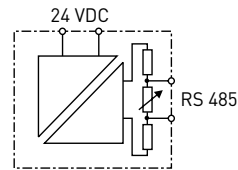

#### Repeater PCD7.T100

This allows the RS 485 bus to be extended and simultaneously divided into 2 bus segments with mutual electrical isolation. Bus frequency is adjustable between 110 bit/s and 500 kbit/s.

Repeaters also allow tree structures to be produced, with up to 3 repeaters being switchable in series.

Order reference: **PCD7.T100**

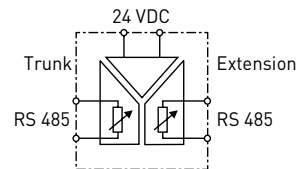

Ordering information:

Typ	Description
<b>SBUS-RAIL</b> (mounting on top-hat rail)	
PCD7.L100	Input module with 4 digital inputs, 24 VDC
PCD7.L200	Output module with 4 relays 250 VAC/6 A
PCD7.L300	Analogue module with 4 inputs each Pt 1000 and 0...10 VDC
PCD7.L310	Analogue module with 4 inputs each Ni 1000 and 0...10 VDC
PCD7.L400	Analogue module with 4 outputs 0...10 VDC
<b>SBUS-SAFE</b> (surface mount)	
PCD7.L101	Input module with 4 digital inputs, 24 VDC
PCD7.L201	Output module with 4 relays 250 VAC/10 A
PCD7.L301	Analogue module with 4 inputs each Pt 1000 and 0...10 VDC
PCD7.L311	Analogue module with 4 inputs each Ni 1000 and 0...10 VDC
PCD7.L401	Analogue module with 4 outputs 0...10 VDC

# Technical data SAIA®S-Bus protocol

PCD controllers supported	Included in the operating system of all PCD CPUs
Interfaces supported	RS 232, RS 422, RS 485, TTY/20 mA current loop, modem, Ethernet-TCP/IP
Reliability	CRC 16 error recognition (Hamming distance 4)
Transmission speed	S-Bus via serial ports adjustable to max. 38.4 kBd S-Bus via Ethernet-TCP/IP 10/100 MBd (autosensing)
Addressing	In RS 485 network, up to 254 stations in segments of 32 stations each; with Ethernet-TCP/IP, multiples of 254 stations
Distances	In RS 485 network max. 1200 m per segment, with 3 repeaters max. 4800 m. With specially selected cable, optical fibres, or Ethernet-greater distances are also possible.
Communications principle	Master/slave procedure or half-duplex mode in RS 485 bus. Multimaster communication in Ethernet
Services available	Level 1 for data transfer Level 2 (PGU) for programming, commissioning and debugging
Data transfer service	Supports the reading and writing of all PCD data (I/Os, flags, registers, timers/counters, data blocks, clock, etc.)
Programming service	All PG5 functions can be used via the chosen interface (program download, online connections, debugger, etc.)
Number of interfaces	Level 1 service can be assigned to several interfaces simultaneously and used. Level 2 service can be configured and used on one interface per CPU.
Broadcast telegrams	Are supported
Gateway function	Supports the connection of 3 additional external master devices with access to slave devices. Via Ethernet-TCP/IP any number of master devices can access slave devices.
Connection to SCADA	Achieved with the SAIA®OPC server or with DLL libraries and external systems for Windows
Access protection	Access via the level 2 service can be password protected.
Configuration + programming	In the PG5 programming tool with simple IL instructions and/or convenient FUPLA FBoxes
Diagnosis	Extensive diagnostic capabilities with IL instructions, FUPLA FBoxes and in the PG5 programming tool

## Saia-Burgess Controls Ltd.

Bahnhofstrasse 18  
CH-3280 Murten/Switzerland

Telephone ++41 26 672 71 11  
Telefax ++41 26 670 44 43

E-mail: [pcd@saia-burgess.com](mailto:pcd@saia-burgess.com)  
Homepage: [www.saia-burgess.com](http://www.saia-burgess.com)  
Support: [www.sbc-support.ch](http://www.sbc-support.ch)

## Saia-Burgess Controls Kft.

Liget utca 1  
H-2040 Budaörs

Telephone 023/501 170  
Telefax 023/501 180

E-mail: [office@saia-burgess.hu](mailto:office@saia-burgess.hu)  
Homepage: [www.saia-burgess.hu](http://www.saia-burgess.hu)  
Support: [www.sbc-support.ch](http://www.sbc-support.ch)

## Your local contact: