

Pulsafeeder's special Head Start Assembly (HSA) is designed specifically for the electronic PULSAtron metering pumps at low flows. With an improved double check in the suction and discharge valves and a reduced hold-up volume pump head design, priming and suction lift performance is greatly enhanced. Without priming assistance and with a dry liquid end, the HSA is capable of a four foot suction lift with a reduced priming time.

Description

The HSA is an available option on all PULSAtron series pumps on models with outputs of 24 GPD (3.8 LPH) and less. Designation is made by the letter "J" in the tenth position of the model number and comes in glass filled polypropylene, polyvinyl chloride and polyvinylidene fluoride construction. Valve seat material is PFA and comes in a double seat configuration with either ceramic or 316SS check balls. Available liquid end configurations will be:

- PTCJ
- VTCJ
- KTCJ

Note: C may be replaced with S for 316SS check balls.

Only tubing connections are available with 1/4" ID X 3/8" OD.

Field replaceable conversion kits are available (see back side) and consists of suction/discharge valves and pump head.

Operating Benefits

- Enhanced Priming
- Enhanced Suction Lift



Aftermarket

- Water Meters
- Gauges
- Dampeners
- Pressure Relief Valves
- KOPkits
- Tanks
- Pre-Engineered Systems



PULSAtron® Head Start Assembly

ITEM	PART #	DESCRIPTION			QTY
1	L3201TCJ-FPP	DISCHARGE VALVE	3/8"	FPP	1
	L3201TCJ-PVC		3/8"	PVC	1
	L3201TCJ-PVD		3/8"	PVDF	1
1A	L1100300-FPP	COUPLING NUT	3/8"	FPP	1
	L1100300-PVC		3/8"	PVC	1
	L1100300-PVD		3/8"	PVDF	1
2	L0200900-FPP	PUMP HEAD FOR MODELS		FPP	1
	L0200900-PVC	LB02; LC02; LD02; LE02, 12;		PVC	1
	L0200900-PVD	LPA2, B2, K2		PVDF	1
	L020100-FPP	PUMP HEAD FOR MODELS		FPP	1
	L0201000-PVC	LB03; LC03; LD03; LE03, 13, 33;		PVC	1
	L0201000-PVD	LPA3, B3, D3, K3		PVDF	1
3	L3101TCJ-FPP	SUCTION VALVE	3/8"	FPP	1
	L3101TCJ-PVC		3/8"	PVC	1
	L3101TCJ-PVD		3/8"	PVDF	1
3A	L1100300-FPP	COUPLING NUT	3/8"	FPP	1
	L1100300-PVC		3/8"	PVC	1
	L1100300-PVD		3/8"	PVDF	1

* CONSTRUCTION FPP/TFE/C

FPP = Glass Filled Polypropylene; PVC = Polyvinyl Chloride; PVDF = Polyvinylidene Fluoride; PE = Polyethylene; PEB = Polyethylene Black (UV resistant); PTFE = Polytetrafluoroethylene

Note: 1A and 3A are included with suction and discharge valves.

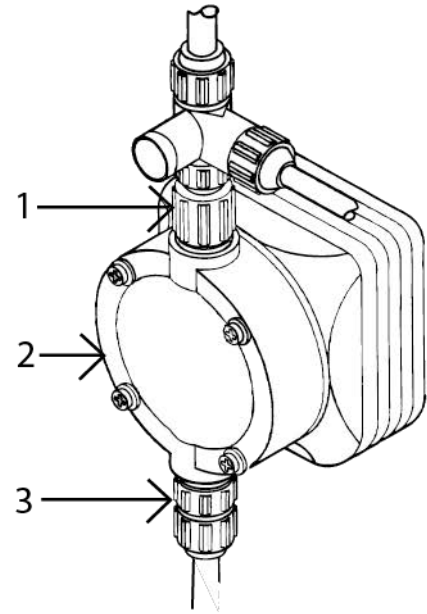

Engineering Data

Pump Head:	GFPPPL
Valve Body:	PVC PVDF
Valve Seats:	Double PFA
Check Balls:	Ceramic 316SS
O-Rings:	PTFE
Maximum Viscosity:	1000 CPS
Maximum Operating Pressure:	300 PSI (21 BAR) (PVC is 150 PSI (10BAR))
Maximum Flow:	33 GPD (37.85 LPH)
Suction Lift:	4 feet dry
Available Models:	LB 02, 03, S2, S3 LC 02, 03 LD 02, 03 LE 02, 03, 12, 13, 33 LP A2, A3, B2, B3, D3, K2, K3

Important: Material Code - GFPPPL=Glass-filled Polypropylene, PVC=Polyvinyl Chloride, PE=Polyethylene, PVDF=Polyvinylidene Fluoride, CSPE=Generic formulation of Hypalon, a registered trademark of E.I. DuPont Company. Viton is a registered trademark of E.I. DuPont Company. PVC wetted end recommended for sodium hypochlorite.

Head Start Assembly Kits

For existing pumps in the field there are Head Start Assembly conversion kits. These kits include all the parts necessary to make your conversion swift and easy. Each kit contains the following: (1) head assembly, (1) suction valve (1) discharge valve, (2) coupling nuts, (4) screws. Please refer to the chart below to determine the correct part number for the conversion kit for your specific model.

PART NUMBER	HEAD/SEAT/BALL	PUMP MODEL USEAGE
L9905000-FPP	FPP/TFE/C	LB02, S2; LC02; LD02; LE02, 12; LPA2, B2, K2
L9905000-PVC	PVC/TFE/C	
L9905000-PVD	PVDF/TFE/C	
L9905100-FPP	FPP/TFE/C	LB03, S3; LC03; LD03; LE03, 13, 33; LPA3, B3, D3, K3
L9905100-PVC	PVC/TFE/C	
L9905100-PVD	PVDF/TFE/C	

pulsafeeder.com



27101 Airport Rd
Punta Gorda, FL 33982
Phone: ++1(941) 575-3832
Fax: ++1(941) 575-4085

An ISO 9001 and ISO 14001 Certified Company



HSA001 D12